



Model E-ITS700-31



Model E-ITS500-31



Model E-ITS100NS-31



Optional Ice Totes accessory allows easy, safe ice distribution! Cart holds 68kg (150 lbs) of ice when Totes are used.

Elevated ice storage bins and castor cart systems. Cart slides into bay below bin for convenient, gravity-fed loading. Ice flows into the castor cart when the hopper door is opened, allowing fast, convenient ice removal. Bins store up to 318 kg (700 lbs) of ice, excluding cart. Cart stores an additional 109 kg (240 lbs) of ice, 68 kg (150 lbs) when used with Totes™ ice carriers accessory. Full stainless exterior on bin and base standard.

Labor-saving design increases convenience and safety

- Gravity loading of ice saves time, eliminates shoveling
- Castor cart rolls easily, quickly to usage area
- Totes ice carriers allows safe, easy ice distribution in displays, salad bars, ice dispensers
- 788 mm (31") width allows use in limited space

All-polyethylene cart provides a better way to move ice within your facility

- Durable, easy-to-clean poly eliminates dents, scratches
- All-poly material reduces damage to walls and fixtures from careless cart drivers
- Oversized wheels make maneuvering easy
- Wide, shallow cart design facilitates removal of ice
- Cart drains to bin drain system when parked in bay

Non-corroding poly liners and hoppers

- Eliminates pitting and staining of liner
- Provides exceptional durability

Totes ice carriers simplifies ice distribution

- Six rugged polyethylene Totes ice carriers nest in cart
- Eliminates need to shovel ice from cart
- Easy, safe way to distribute ice in displays
- Slim design fits easily below breath protectors

Other quality construction features

- Full stainless bin and base standard
- Heavy-duty base with built-in drain for bin and cart
- Single, reversible drain connection
- Durable polyethylene lift door with PowerHinge™ door hinge on E-ITS700-31, inspection window on E-ITS500-31 and E-ITS600-31
- SmartGATE® ice shield positively controls ice flow into access door area for increased safety, reduced spillage (E-ITS700-31 only)
- Stainless tops custom-cut for specific icemaker(s)

Accessories

- Totes ice carriers (set of 6, one set per cart) (item# 206950)
- Additional ice transport cart
- Drain pan (required for Vogt, Howe, Northstar icemakers; consult factory)
- Plastic shovel (item# ABICSHOVEL)
- Ice Paddle and hanging bracket (item# ABICEPADDL)

E-ITS100-31 (without cart in bay)

Front View

Side View

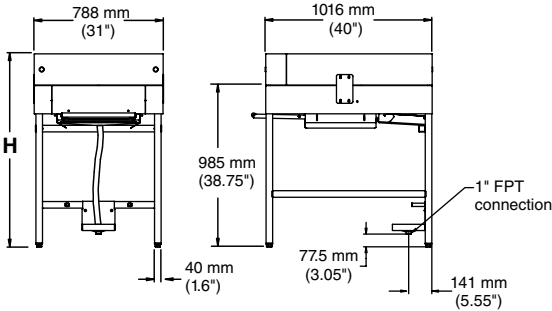

E-ITS500-31/E-ITS600-31 (without cart in bay)

Front View

Side View

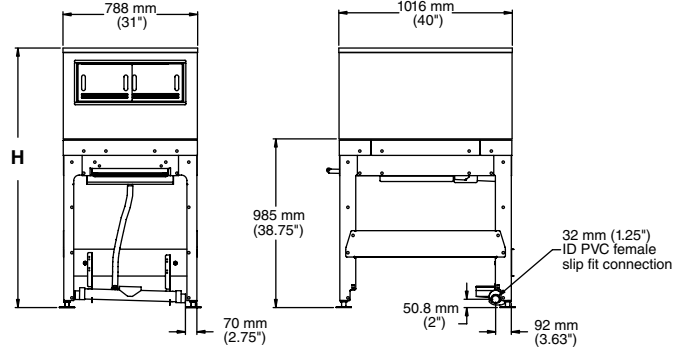

E-ITS700-31 (without cart in bay)

Front View

Side View

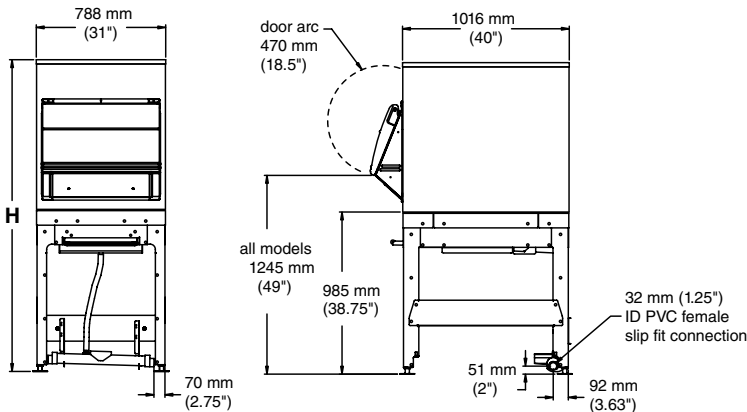

Front View Tote

Side View Tote

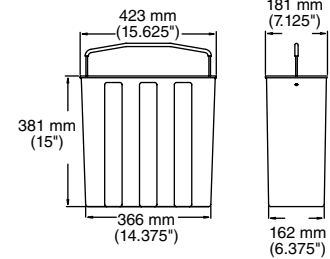

Front View Cart

Side View Cart

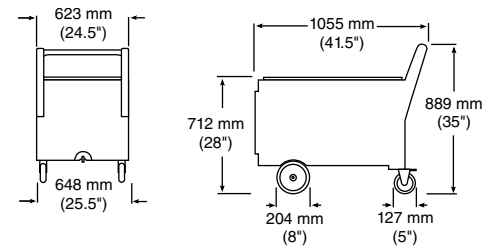

General Notes

- Clearance required to pull cart from bay – minimum 1220 mm (48"), optimal 1372 mm (54")
- Follett recommends installation of a floor drain with grate with all ice storage bins
- Drain connection is reversible to exit at left or right side of unit

Model Number	Max. Bin Cap. kg (lb) ¹	Max. Cap. with Carts kg (lb) ^{1,2}	No. Carts	Width mm (in)	Depth mm (in) ^{3,5}	Depth with Door mm (in) ^{3,5}	Height (H) with Legs mm (in) ⁶	Required Access mm (in) ⁴	Approx. Ship Wt. kg (lb) ⁵
E-ITS100NS-31	45 (100)	154 (340)	1	788 (31)	1016 (40)	N/A	1178 (47)	813 (32)	46 (100)
E-ITS500NS-31	227 (500)	336 (740)	1	788 (31)	1016 (40)	N/A	1524 (60)	813 (32)	227 (500)
E-ITS600NS-31	273 (600)	382 (840)	1	788 (31)	1016 (40)	N/A	1703 (67)	813 (32)	272 (600)
E-ITS700SG-31	318 (700)	426 (940)	1	788 (31)	1016 (40)	1220 (48)	1905 (75)	813 (32)	318 (700)

Notes:

- 1 Computed on cubic capacity of bin. Does not reflect cart capacity or voids that can occur due to pyramiding.
- 2 Each cart holds 109 kg (240 lbs) without optional Totes ice carriers, 68 kg (150 lbs) with Totes ice carriers.
- 3 Door assemblies remove easily (4 screws) if necessary for installation access.
- 4 Required clearance for installation access through doors (may require removal of door assembly).
- 5 Add 51 mm (2") to depth and 4.5 kg (10 lbs) to shipping weight when drain pan accessory used.
- 6 Special top required for icemakers weighing more than 454 kg (1000 lbs). Add 54 mm (2.125") to height. Contact factory.

PowerHinge and Totes are trademarks of Follett Corporation.
 Follett and SmartGATE are registered trademarks of Follett Corporation, registered in the US.
 Follett reserves the right to change specifications at any time without obligation. Certifications may vary depending on country of origin.